

Features

- Ultra-low current consumption: 0.7 μ A (Typ)
- Wide input voltage range: 1.5V to 5.5V
- Fixed output voltages:
 - 0.7V to 5.2V with 100mV/step
- High output voltage accuracy: \pm 1.5%
- Low dropout voltage:
 - 60mV (Typ) at 50mA ($V_{OUT} = 3.3V$)
 - 130mV (Typ) at 100mA ($V_{OUT} = 3.3V$)
- Integrated over-current protection
- Support 1.8V logic EN pin
- Robust ESD capability:
 - Human Body Model: 2 kV
 - Charged Device Model: 0.5 kV
- Available in small packages:
 - TDFN-4L, 1.0mm \times 1.0mm

Applications

- Wearable Devices
- Portable Medical Equipment
- PDAs, Mobile Phones GPS devices

Ordering Information

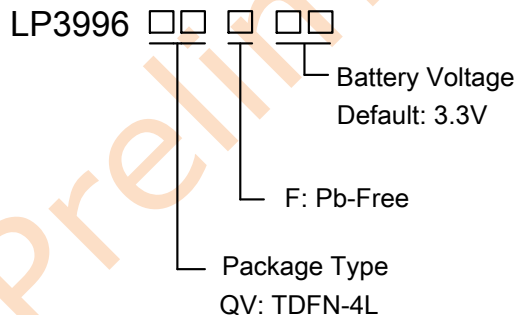

Description

The LP3996 is a low-dropout voltage regulator with low quiescent current and in ultra-small package. The LP3996 can deliver output current up to 250mA. It offers different output voltage within 0.7V to 5.2V.

The LP3996 is integrated over current protection and short circuit protection in order to protect system abnormal.

The output capacitor as small as 0.1 μ F is good enough for LP3996.

The LP3996 is available in 4 pins ultra-small DFN package with only 1mm \times 1mm size.



TDFN-4 1mm x 1mm

Marking Information

Device	Marking	Package	Shipping
LP3996QVF	xxx	TDFN-4	4K/Reel



Application Diagram

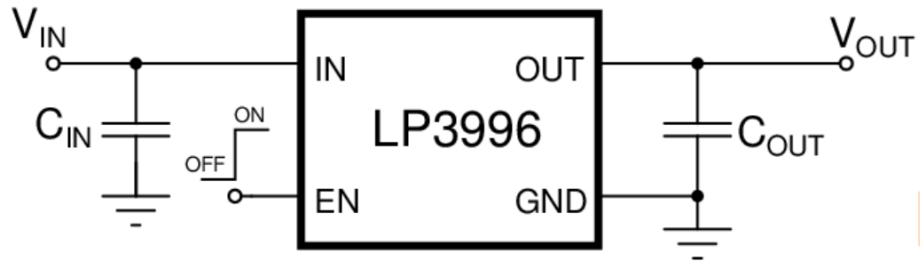

Pin Configuration

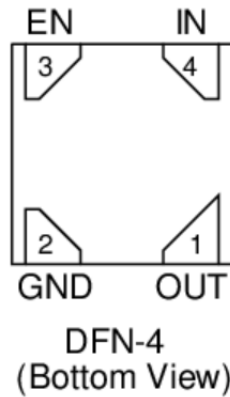

Pin Description

Pin No. TDFN-4	Name	Description
4	IN	Input and power source. A small capacitor is recommended from this pin to ground.
2	GND	Ground.
3	EN	Active-high enable pin. 1: enable the device. 0 or floating: disable the device.
-	NC	Not connected.
1	OUT	Regulated output. A minimum 0.1μF ceramic capacitor is needed from it to ground.



Functional Block Diagram

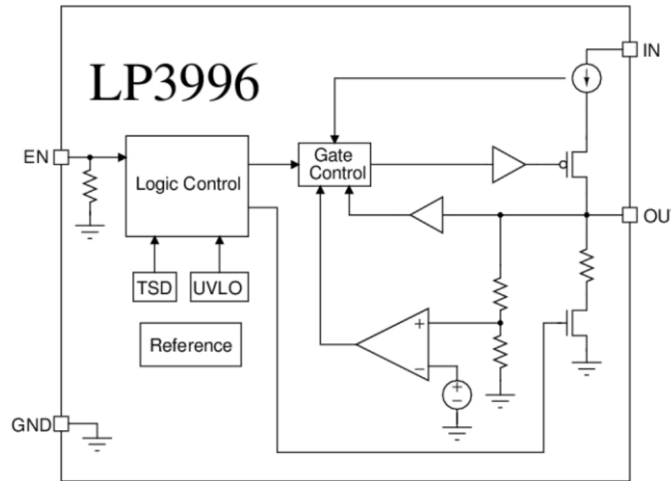

Absolute Maximum Ratings (Note 1)

- IN to GND ----- -0.3V to 6.5V
- OUT to GND ----- -0.3V to (V_{IN} + 0.3V) or 6.5V
- EN to GND ----- -0.3V to 6.5V
- Output Current ----- 1mA to 300mA
- Maximum Junction Temperature (T_J) ----- 150°C
- Maximum Soldering Temperature (At leads, 10 sec) ----- 260°C

*Note 1: Stresses beyond those listed under “Absolute Maximum Ratings” may cause permanent damage to the device. These are stress ratings only, and functional operation of the device at these or any other conditions beyond those indicated in the operational sections of the specifications is not implied. Exposure to absolute maximum rating conditions for extended periods may affect device reliability.

Thermal Information

- Maximum Power Dissipation (TDFN-4L, P_D, T_A ≤ 25°C) ----- 390mW
- Thermal Resistance (TDFN-4L, θ_{JA}) (Note 2) ----- 256 °C/W

*Note 2: Measured using 2S2P JEDEC standard PCB with ambient temperature < 25°C

Electro-Static Discharge and Latch-up

- HBM (Human Body Model, JEDEC JS-001) ----- 2000V
- CDM (Charged Device Model, JEDEC JS-002) ----- 500V

Recommended Operating Conditions

- Input and supply voltage on IN ----- 1.5V to 5.5V
- Output DC current ----- 1mA to 250mA
- Output capacitor ----- > 0.1µF
- Operating ambient temperature ----- -40°C to 85°C



Electrical Characteristics

The parameters are specified under conditions: V_{IN} is equal to the greater value between $V_{OUT(NOM)} + 0.5V$ and $2.0V$, $-40^{\circ}C \leq T_J \leq 85^{\circ}C$, $I_{OUT} = 1mA$, $C_{IN} = C_{OUT} = 1\mu F$, unless otherwise noted. Typical values are at $T_J = 25^{\circ}C$.

Parameter	Symbol	Test Conditions	Min	Typ.	Max	Units
Output voltage accuracy		$V_{OUT(NOM)} \leq 1.5V$, $T_J = 25^{\circ}C$	-15		15	mV
		$V_{OUT(NOM)} > 1.5V$, $T_J = 25^{\circ}C$	-1.5		1.5	%
Output voltage accuracy over temperature		$V_{OUT(NOM)} \leq 1.5V$	$-40^{\circ}C \leq T_J \leq 85^{\circ}C$	-20	20	mV
		$V_{OUT(NOM)} > 1.5V$		-2.0	2.0	%
Input quiescent current	I_Q	$V_{IN} = 1.5V$ to $5.5V$, $V_{EN} = V_{IN}$, no load		0.7		μA
Input shutdown current	I_{SHDN}	$V_{IN} = 1.5V$ to $5.5V$, $V_{EN} = 0V$, no load		0.1		μA
Line regulation	$\frac{\Delta V_{OUT}}{\Delta V_{IN} \times V_{OUT}}$	$I_{OUT} = 1mA$, $V_{IN} = (V_{OUT(NOM)} + 1.5V)$ to $6V$		0.05	0.15	%/V
Load regulation	ΔV_{LOAD}	$I_{OUT} = 1mA$ to $100mA$, $V_{IN} = V_{OUT(NOM)} + 1.5V$, $-40^{\circ}C \leq T_J \leq 85^{\circ}C$		15	40	mV
Dropout voltage in TDFN-4	V_{DROP}	$V_{OUT(NOM)} = 1.2V$, $I_{OUT} = 50mA$, $T_A = 25^{\circ}C$		0.42	0.7	V
		$V_{OUT(NOM)} = 1.8V$, $I_{OUT} = 50mA$, $T_A = 25^{\circ}C$		0.16	0.3	
		$V_{OUT(NOM)} = 3.3V$, $I_{OUT} = 50mA$, $T_A = 25^{\circ}C$		0.08	0.15	
		$V_{OUT(NOM)} = 1.2V$, $I_{OUT} = 100mA$, $T_A = 25^{\circ}C$		0.65	1.1	
		$V_{OUT(NOM)} = 1.8V$, $I_{OUT} = 100mA$, $T_A = 25^{\circ}C$		0.30	0.6	
		$V_{OUT(NOM)} = 3.3V$, $I_{OUT} = 100mA$, $T_A = 25^{\circ}C$		0.14	0.3	
Output current limit	I_{LIM}	$V_{OUT(NOM)} < 1.5V$, $V_{IN} = V_{OUT(NOM)} + 1.5V$, $V_{OUT} = 0.9 \times V_{OUT(NOM)}$		300		mA
		$V_{OUT(NOM)} \geq 1.5V$, $V_{IN} = V_{OUT(NOM)} + 1.0V$, $V_{OUT} = 0.9 \times V_{OUT(NOM)}$		300		
Short circuit protection	I_{SHORT}	$V_{IN} = V_{OUT(NOM)} + 1.0V$, $V_{OUT} = 0V$		50		mA
Output voltage noise	V_{NOISE}	$BW = 10Hz$ to $100kHz$, $I_{OUT} = 30mA$		330		μV_{RMS}
Power supply rejection ratio	PSRR	$V_{IN} = V_{OUT(NOM)} + 1.5V$, $I_{OUT} = 30mA$, $f = 1kHz$, $\Delta V_{RIPPLE} = 0.2 \times V_{PP}$		24		dB
EN logic high voltage level	V_{IH}		1.1			V
EN logic low voltage level	V_{IL}				0.3	V
EN pin leakage current	I_{EN}			30		nA
EN pull down resistance	R_{EN}					M Ω



Typical Waveforms and Characteristics

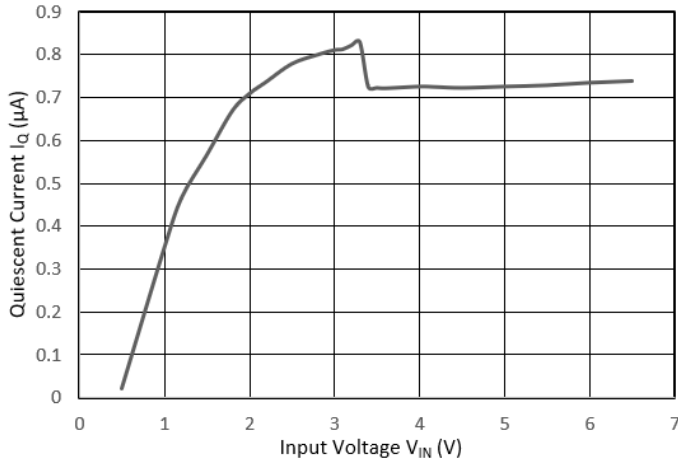

Figure 4. Quiescent Current vs Input Voltage (C_{IN}=C_{OUT}=1µF, V_{EN}=V_{IN}, no load)

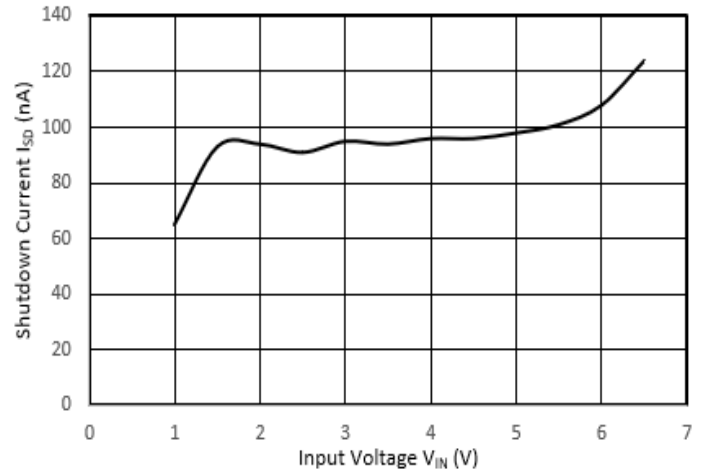

Figure 5. Shutdown Current vs Input Voltage (C_{IN}=C_{OUT}=1µF, V_{EN}=0V, no load)

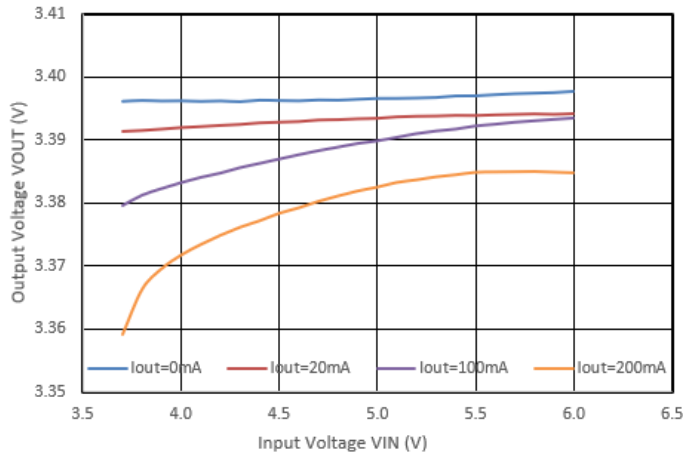

Figure 8. Output Voltage vs Output Current (C_{IN}=C_{OUT}=1µF, V_{OUT}=3.4V, T_A = 25°C)

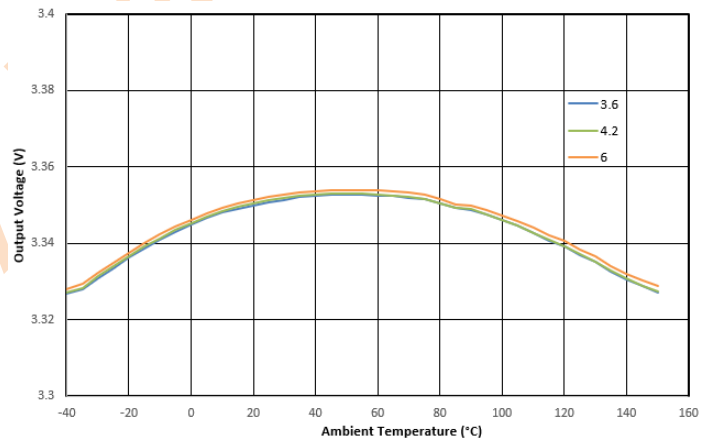

Figure 9. Output Voltage vs Temperature (C_{IN}=C_{OUT}=1µF, V_{OUT}=3.4V, V_{IN} = 3.6V, 4.2V, 6.0V)

Function Description

Overview

The LP3996 is a Low dropout voltage regulator with ultra-low current consumption. It has fixed output voltage with good transient performance. The product is available in ultra-small package 1mm x 1mm TDFN-4.

Selectable output voltage

The product will output fixed voltage as long as the input voltage is higher than $V_{OUT(NOM)} + V_{DROP}$. $V_{OUT(NOM)}$, the output voltage, can be selected from 0.7V to 5.2V (100mV/step) and can source up to 200mA loading current.

Enable function

The EN pin is an active high Logic input pin that is compatible with 1.2V control logic. The internal power element is turned off when EN pin is tied low.

When the EN pin is pulled high, the LP3996 will be activated and output voltage according to setting.

Over current protection

The device features a current limit function when the over current event is detected to reach 300mA (Typ) and output voltage will drop accordingly. In the heavy load condition, the current limit value will be reduced along with output voltage drops. If the output is shorted to ground, the current limit value will foldback to smaller, 50mA, as in the *Electrical Characteristics Table*.

Application Information

Capacitor consideration

External capacitors on IN and OUT are recommended in application, 0.1 μ F for C_{OUT} and 1 μ F for C_{IN} at least. Closer placement of the capacitors to the device, both IN and OUT, would be better for stability.

Power Dissipation

The internal power dissipation from the power MOSFET, when it is turned on, is the main source of junction temperature rising. In this case, the power dissipation and the junction temperature in conducting mode can be calculated as following:

$$P_D = (V_{IN} - V_{OUT}) \times I_{OUT}$$

P_D : Power Dissipation (W)

V_{IN} : Input voltage (V)

V_{OUT} : Output voltage (V)

I_{OUT} : Output current (A)

$$T_J = P_D \times \theta_{JA} + T_A$$

T_J : Junction temperature ($^{\circ}$ C)

θ_{JA} : Package thermal resistance ($^{\circ}$ C /W) (Note 4)

T_A : Ambient temperature ($^{\circ}$ C)

***Note 4: The calculation base on thermal resistance is only valid in Lab condition. The value of θ_{JA} could change in customer PCB environment.**



Package Dimensions

TDFN-4, 1mm x 1mm

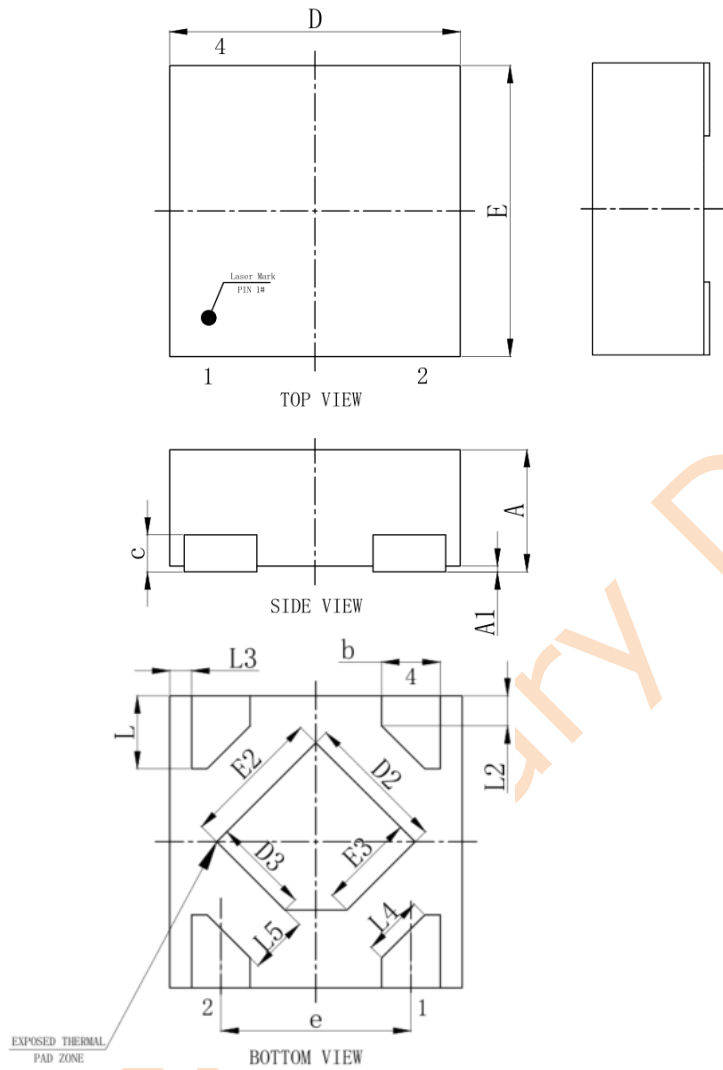

SYMBOL	MILLIMETER		
	MIN	NOM	MAX
A	0.35	-	0.40
A1	0.00	0.02	0.05
b	0.15	0.20	0.25
c	0.127REF		
D	0.95	1.00	1.05
D2	0.38	0.48	0.58
D3	0.23	0.33	0.43
e	0.65BSC		
E	0.95	1.00	1.05
E2	0.38	0.48	0.58
E3	0.23	0.33	0.43
L	0.20	0.25	0.30
L2	0.103REF		
L3	0.075REF		
L4	0.208REF		
L5	0.200REF		